

VHDL 200X: The Future of VHDL

By Jim Lewis
SynthWorks VHDL Training
Team Leader VHDL-200X Fast Track
jim@synthworks.com

VHDL-200X: The Future of VHDL

SynthWorks

- VHDL-200X started as an IEEE effort, however, no \$\$\$
- Transitioned to Accellera with funding through membership.
- Goal for VHDL-2006,
 - merge the IEEE & Accellera proposals
 - Prioritize proposals
 - Update the LRM on the basis of the issue/proposals priority.
- Guidelines:
 - Maintain VHDL style, nature, and backward compatibility
 - Leverage Industry Efforts (PSL, SystemVerilog, ...)

Caution: Changes presented here are a work in progress

VHDL-200X-FT: Proposals

- PSL
- IP Protection
- Type Generics
- Generics on Packages
- Arrays with unconstrained arrays
- Records with unconstrained arrays
- Fixed Point Packages
- Floating Point Packages
- Process(all)
- Case Statement Updates
- Don't Care in a Case Statement
- Conditional Expression Updates
- Expressions in port maps
- Read out ports
- Stop and Finish
- If Expressions
- Conditional and Selected assignment in sequential code
- hwrite, owrite, ... hread, oread
- to_string, to_hstring, ...
- Sized bit string literals
- Unary Reduction Operators
- Array/Scalar Logic Operators
- Hierarchical references of signals
- Slices in array aggregates
- Std_logic_1164 Updates
- Numeric_Std Updates

Much of VHDL's cumbersome syntax issues can be fixed

Accellera Additions

- Random value generation with dynamic weighting
 - aka Constrained Random
- Randomly generate sequences of stimulus
- Functional Coverage
- Interfaces
- If-generate with Else and Elself clause
- Case Generate
- Memories w/ loading and dumping
- Support Associative Arrays

Unfortunately it is too early to comment on these

PSL

- PSL will be incorporated directly into VHDL
- Implications
 - PSL Vunits are a VHDL Design Unit
 - PSL declarations (properties) can go in:
 - Packages
 - Declarative regions of entity, architecture, and block.
 - PSL directives (assert, cover, ...) are VHDL statements
 - Can be placed in any concurrent statement part.

Note: PSL code will not need to be placed in comments

Type Generics + Generics on Packages

```

package MuxPkg is
  generic( type array_type) ;
  function Mux4 (
    Sel : std_logic_vector(1 downto 0);
    A   : array_type ;
    B   : array_type ;
    C   : array_type ;
    D   : array_type
  ) return array_type ;
end MuxPkg ;
package body MuxPkg is
  . . .
end MuxPkg ;

```

Type Generics + Generics on Packages

- Making the Mux4 function available for both std_logic_vector and unsigned.

```

library ieee ;
package MuxPkg_slv is new work.MuxPkg
  Generic map (
    array_type => ieee.std_logic_1164.std_logic_vector
  ) ;

library ieee ;
package MuxPkg_unsigned is new work.MuxPkg
  Generic map (
    array_type => ieee.numeric_std.unsigned
  ) ;

```

Arrays of Unconstrained Arrays

```

type std_logic_matrix is array (natural range <>)
  of std_logic_vector ;

-- constraining in declaration
signal A : std_logic_matrix(7 downto 0)(5 downto 0) ;

entity e is
port (
  A : std_logic_matrix(7 downto 0)(5 downto 0) ;
  . . .
) ;

```

Records of Unconstrained Arrays

```

type complex is record
  a : std_logic ;
  re : signed ;
  im : signed ;
end record ;

-- constraining in declaration
signal B : complex (re(7 downto 0), im(7 downto 0)) ;

```

Fixed Point Types

- Definitions in package, `ieee.fixed_pkg.all`

```

type ufixed is array (integer range <>) of std_logic;
type sfixed is array (integer range <>) of std_logic;

```

- For `downto` range, whole number is on the left and includes 0.

```

constant A : ufixed (3 downto -3) := "0011010000" ;

  3210 -3
  IIIIFFF
  0110100 = 0110.100 = 6.5

```

- Math is full precision math:

```

signal A, B : ufixed (3 downto -3) ;
signal Y    : ufixed (4 downto -3) ;
. . .
Y <= A + B ;

```

Floating Point Types

- Definitions in package, `ieee.float_pkg.all`

```
type float is array (integer range <>) of std_logic;
```

- Format is Sign Bit, Exponent, Fraction

```
signal A, B, Y : float (8 downto -23) ;

  8  76543210  12345678901234567890123
  S  EEEEEEEE  FFFFFFFFFFFFFFFFFFFFFFFF

E = Exponent has a bias of 127
F = Fraction has an implied 1 in leftmost bit

0  10000000  000000000000000000000000 = 2.0
0  10000001  101000000000000000000000 = 6.5
0  01111100  000000000000000000000000 = 0.125 = 1/8

Y <= A + B ; -- FP numbers must be same size
```

Hierarchical Reference *

- For the near term use a package based approach

```
Procedure Drive(
  source           : in string ;
  target           : in string ;
  force_mode       : in force_mode_type := DEFAULT ;
  verbose          : in boolean := FALSE
) ;

Procedure Probe(
  observer         : in string ;
  source           : in string ;
  verbose          : in boolean := FALSE
) ;
```

- * Inspired by donations from Mentor (Signal Spy) and Cadence (NCMirror)

Hierarchical Reference

```

procedure force (
    target      : in string ;
    value       : in string ;
    delay       : in time := 0 ns ;
    delay_mode  : in delay_mode_type := TRANSPORT_DELAY;
    force_mode  : in force_mode_type := DEFAULT;
    cancel_period : in time := -1 fs ;
    verbose     : in boolean := FALSE
);

procedure release (
    target      : in string ;
    keep_value  : in boolean := FALSE ;
    verbose     : in boolean := FALSE
);

function get_value(
    target      : in string ;
    verbose     : in boolean := FALSE
) return string ;

```

Simplified Case Statement

- Allow locally static expressions to contain:
 - implicitly defined operators that produce composite results
 - operators and functions defined in `std_logic_1164`, `numeric_std`, and `numeric_unsigned`.

```

constant ONE1      : unsigned := "11" ;
constant CHOICE2   : unsigned := "00" & ONE1 ;
signal A, B        : unsigned (3 downto 0) ;
. . .
process (A, B)
begin
    case A xor B is
        when "0000"      =>    Y <= "00" ;
        when CHOICE2     =>    Y <= "01" ;
        when "0110"     =>    Y <= "10" ;
        when ONE1 & "00" =>    Y <= "11" ;
        when others      =>    Y <= "XX" ;
    end case ;
end process ;

```

Simplified Case Statement

- Although concatenation is specifically allowed, some cases will still require a type qualifier.

```

signal A, B, C, D : std_logic ;
. . .

process (A, B, C, D)
begin
  case std_logic_vector'(A & B & C & D) is
    when "0000" => Y <= "00" ;
    when "0011" => Y <= "01" ;
    when "0110" => Y <= "10" ;
    when "1100" => Y <= "11" ;
    when others => Y <= "XX" ;
  end case ;
end process ;

```

Case With Don't Care

- Allow use of '-' in targets provided targets are non-overlapping

```

-- Priority Encoder
process (Request)
begin
  case? Request is
    when "1---" => Grant <= "1000" ;
    when "01--" => Grant <= "0100" ;
    when "001-" => Grant <= "0010" ;
    when "0001" => Grant <= "0001" ;
    when others => Grant <= "0000" ;
  end case ;
end process ;

```

Note: Only '-' in the case target is treated as a don't care.
A '-' in the case? Expression will not be treated as a don't care.

Simplified Conditional Expressions

- Applies to conditional of: if, elsif, wait until, when, while

```
if (Cs1 and not nCs2 and Cs3 and Addr=X"A5") then
if (Cs1 and nCs2='0' and Cs3 and Addr=X"A5") then
if (not nWe) then
```

- Active low is represented with "not nCs2"

```
Sel <= Cs1 and not nCs2 and Cs3 ;
```

- Backward compatible with current VHDL syntax:

```
if nWe = '0' then
if (Cs1='1' and nCs2='0' and Addr=X"A5") then
if ((Cs1 and not nCs2)='1' and Addr=X"A5") then
```

Simplified Conditional Expressions

- Implementation Part 1:

If top level of a conditional expression is either bit or std_ulogic, then call the function condition? to do the conversion.

- This makes the following legal:

```
if (Cs1 and not nCs2 and Cs3) then
```

- Implementation Part 2:

Overload logic operators so if boolean used with bit/std_ulogic, then the result will be bit/std_ulogic

- Maintains accuracy by promoting true to '1' and false to '0'
- This makes the following legal:

```
if (Cs1 and not nCs2 and Cs3 and Addr=X"A5") then
DevSel1 <= Cs1 and not nCs2 and Cs3 and Addr=X"A5" ;
```

Process (all)

- Creates a sensitivity list with all signals on sensitivity list

```
Mux3_proc : process(all)
begin
  case MuxSel is
    when "00" =>      Y <= A ;
    when "01" =>      Y <= B ;
    when "10" =>      Y <= C ;
    when others =>    Y <= 'X' ;
  end case ;
end process
```

- Benefit: Reduce mismatches between simulation and synthesis

Hwrite, Hread, Owrite, Oread

- Support Hex and Octal read & write for all bit based array types

```
procedure hwrite (
  Buf           : inout Line ;
  VALUE         : in integer;
  JUSTIFIED     : in SIDE := RIGHT;
  FIELD        : in WIDTH := 0
) ;

procedure hread (
  Buf           : inout Line ;
  VALUE         : out integer;
  Good          : out boolean
) ;

procedure oread ( . . . ) ;
procedure owrite ( . . . ) ;
```

- No new packages. Supported in base package
 - For backward compatibility, std_logic_textio will be empty

To String, To HString, To OString

- Create to_string for all types.
- Create hex and octal functions for all bit based array types

```
function to_string (
    VALUE          : in std_logic_vector;
    JUSTIFIED      : in SIDE := RIGHT;
    FIELD          : in WIDTH := 0
) return string ;
function to_hstring ( . . . ) return string ;
function to_ostring ( . . . ) return string ;
```

- Formatting Output with Write (not write from TextIO):

```
write(Output, "%%ERROR data value miscompare." &
    NL & " Actual value = " & to_hstring (Data) &
    NL & " Expected value = " & to_hstring (ExpData) &
    NL & " at time: " & to_string (now, right, 12)) ;
```

Sized Bit String Literals

- Currently hex bit string literals are a multiple of 4 in size

```
X"AA" = "10101010"
```

- Allow specification of size (and decimal bit string literals):

```
7X"7F" = "1111111"
7D"127" = "1111111"
```

- Allow specification of signed vs unsigned (extension of value):

```
9UX"F" = "000001111"   Unsigned 0 fill
9SX"F" = "111111111"   Signed: left bit = sign
9X"F" = "000001111"   Defaults to unsigned
```

- Allow Replication of X and Z

```
7X"XX" = "XXXXXXXX"
7X"ZZ" = "ZZZZZZZZ"
```

Signal Expressions in Port Maps

```
U_UUT : UUT
  port map ( A, Y and C, B) ;
```

- Needed to avoid extra signal assignments with OVL
- If expression is not a single signal, constant, or does not qualify as a conversion function, then
 - convert it to an equivalent concurrent signal assignment
 - and it will incur a delta cycle delay

Read Output Ports

- Read output ports
 - Value read will be locally driven value
- Assertions need to be able to read output ports

Allow Conditional Assignments for Signals and Variables in Sequential Code

- State-machine code:

```

if (FP = '1') then
    nextState <= FLASH ;
else
    nextState <= IDLE ;
end if ;

```

- Simplification (new part is that this is in a process):

```

nextState <= FLASH when (FP = '1') else IDLE ;

```

- Also support conditional variable assignment:

```

nextState := FLASH when (FP = '1') else IDLE ;

```

Allow Selected Assignments for Signals and Variables in Sequential Code

```

signal A, B, C, D, Y : std_logic ;
signal MuxSel : std_logic_vector(1 downto 0) ;
. . .
Process(clk)
begin
    wait until Clk = '1' ;
    with MuxSel select
        Mux :=
            A when "00",
            B when "01",
            C when "10",
            D when "11",
            'X' when others ;

    Yreg <= nReset and Mux ;
end process ;

```

IF Expressions

- Similar to conditional signal assignment ...

```
Y <= A and B if S = '1', C and D ;
Y <= (A and B) if S = '1', (C and D) ;
```

- ... except it is an expression:

```
Y <= A and (B if S = '1', C) and D ;
```

- And it can be used anywhere an expression can:

```
Signal A : integer := 7 if GEN_VAL = 1, 15 ;

with MuxSel select
  Y <= (A if Asel='1', B) when '0',
       (C if Csel='1', D) when '1',
       'X' when others ;
```

Unary Reduction Operators

- Define unary AND, OR, XOR, NAND, NOR, XNOR

```
function "and" ( anonymous: BIT_VECTOR) return BIT;
function "or" ( anonymous: BIT_VECTOR) return BIT;
function "nand" ( anonymous: BIT_VECTOR) return BIT;
function "nor" ( anonymous: BIT_VECTOR) return BIT;
function "xor" ( anonymous: BIT_VECTOR) return BIT;
function "xnor" ( anonymous: BIT_VECTOR) return BIT;
```

- Calculating Parity with reduction operators:

```
Parity <= xor Data ;
```

- Calculating Parity without reduction operators:

```
Parity <= Data(7) xor Data(6) xor Data(5) xor
         Data(4) xor Data(3) xor Data(2) xor
         Data(1) xor Data(0) ;
```

Array / Scalar Logic Operators

- Overload logic operators to allow:

```

signal ASel : std_logic ;
signal T, A : std_logic_vector(3 downto 0) ;
. . .
T <= (A and ASel) ;

```

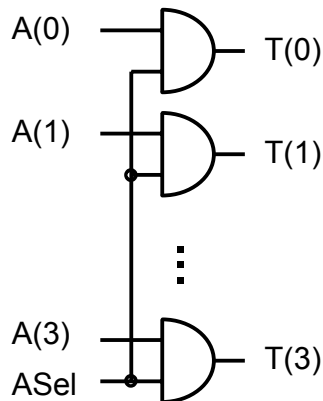

The value of ASel will be replicated to form an array.

When ASel = '0', value expands to "0000"

When ASel = '1', value expands to "1111"

Array / Scalar Logic Operators

- A common application is to data read back logic

```

signal Sel1, Sel2, Sel3, Sel4 : std_logic ;
signal DO, Reg1, Reg2, Reg3, Reg4
      : std_logic_vector(3 downto 0) ;
. . .
DO <= (Reg1 and Sel1) or (Reg2 and Sel1) or
      (Sel3 and Reg3) or (Sel4 and Reg4) ;

```

Slices in Array Aggregates

- Allow slices in an Array Aggregate

```

Signal A, B, Y      : unsigned (7 downto 0) ;
signal CarryOut    : std_logic ;

. . .

(CarryOut, Y) <= ('0' & A) + ('0' & B) ;

```

- Currently, this would have to be written as:

```

(CarryOut, Y(7), Y(6), Y(5), Y(4), Y(3), Y(2), Y(1), Y(0))
  <= ('0' & A) + ('0' & B) ;

```

Std Logic 1164 Updates

- Goals: Enhance current std_logic_1164 package
- A few items on the list are:
 - Uncomment xnor operators
 - Add shift operators for vector types
 - Add logical reduction operators
 - Add array/scalar logical operators
 - Match Function
 - Provide text I/O package for standard logic (similar to Synopsys' std_logic_textio)
- See also DVCon 2003 paper, "Enhancements to VHDL's Packages" which is available at:
 - <http://www.synthworks.com/papers>

Numeric Std Updates

- Goals:
 - Enhance current numeric_std package.
 - Unsigned math with std_logic_vector/std_ulogic_vector
- A few items on the numeric_std list are:
 - Logic reduction operators
 - Array / scalar logic operators
 - Array / scalar addition operators
 - TO_X01, IS_X for unsigned and signed
 - TextIO for numeric_std

Resulting Operator Overloading

<u>Operator</u>	<u>Left</u>	<u>Right</u>	<u>Result</u>
Logic	TypeA	TypeA	TypeA
Numeric	Array	Array	Array*
	Array	Integer	Array*
	Integer	Array	Array*
Logic, Addition	Array	Std_ulogic	Array
	Std_ulogic	Array	Array
Logic Reduction		Array	Std_ulogic
<u>Notes:</u>			
Array = std_ulogic_vector, std_logic_vector, bit_vector unsigned, signed,			
TypeA = boolean, std_logic, std_ulogic, Array			
For Array and TypeA, arguments must be the same.			
* for comparison operators the result is boolean			

Stop and Finish

- Add procedures STOP and FINISH:
 - STOP - Stops like breakpoint
 - FINISH - Terminate the simulation

```
procedure STOP;  
procedure FINISH;
```

- Benefit:
 - Just stop. No annoying messages.

IP Protection and Encryption

- A pragma-based approach
- Allows IP authors to mark specific areas of VHDL code for encryption using standard algorithms.
- The proposal:
 - Defines constructs to demarcate protected envelopes in VHDL source code.
 - Defines keywords to specify algorithms and keys.
- Tools that work with encrypted IP must not reveal any details through any interface or output it generates.
 - For example, a synthesis tool should generate an encrypted netlist for any portion of a design that is encrypted.

VHDL-200X, Summary, part 1

- Expected completion is mid-2006.
- Next Steps are to add:
 - Verification Data Structures such as
 - associative arrays, queues, FIFOs, and memories
 - Constrained Random Stimulus Generation
 - Direct C and Verilog/SystemVerilog Calls
 - Object Orientation
- Goal = HDVL: Hardware Description and Verification Language
 - Full verification capabilities in one consistent language

VHDL-200X: Summary

- We need your help:
 - Participate! Don't sit on the bench and wait and watch.
 - See <http://www.accellera.org/activities/vhdl/>
 - Ask your colleagues and vendors to participate
 - Tell your vendors about features you want supported.
 - Be specific and prioritize your requests
 - Join Accellera and help fund the effort
 - Corporate membership
- VHDL-200X = 200 X better than ...

SynthWorks & VHDL Standards

- At SynthWorks, we are committed to see that VHDL is updated to incorporate the good features/concepts from other HDL/HVL languages such as SystemVerilog, E (specman), and Vera.
- At SynthWorks, we invest 100's of hours each year working on VHDL's standards
- Support VHDL's standards efforts by:
 - Encouraging your EDA vendor(s) to support VHDL standards,
 - Participating in VHDL standards working groups, and / or
 - Purchasing your VHDL training from SynthWorks

SynthWorks VHDL Training

Comprehensive VHDL Introduction 4 Days

http://www.synthworks.com/comprehensive_vhdl_introduction.htm

A design and verification engineer's introduction to VHDL syntax, RTL coding, and testbenches. Students get VHDL hardware experience with our FPGA based lab board.

VHDL Testbenches and Verification 3 days

http://www.synthworks.com/vhdl_testbench_verification.htm

Learn to simplify writing tests by creating transaction-based testbenches.

Intermediate VHDL Coding for Synthesis 2 Days

http://www.synthworks.com/intermediate_vhdl_synthesis.htm

Learn RTL (hardware) coding styles that produce better, faster, and smaller logic.

Advanced VHDL Coding for Synthesis 2 Days

http://www.synthworks.com/advanced_vhdl_synthesis.htm

Learn to avoid RTL coding issues, problem solving techniques, and advanced VHDL constructs.

For additional courses see: <http://www.synthworks.com>